

# ADVANCED HIGH CEILING Signum 16 - Adjustable Cable



## IMPORTANT SAFETY INFORMATION. READ AND FOLLOW ALL SAFETY INSTRUCTIONS

IMPORTANT SAFETY INFORMATION. READ AND FOLLOW ALL SAFETY INSTRUCTIONS. Before wiring to power supply and during servicing or relamping, turn off power at fuse or circuit breaker. All servicing or relamping must be performed by qualified service personnel. Product must be grounded to avoid potential electric shock or other potential hazard. Product must be at locations and at heights and in a manner consistent with its intended use, and in compliance with Electrical Code and local codes.

**SAVE THESE INSTRUCTIONS FOR FUTURE REFERENCE.**

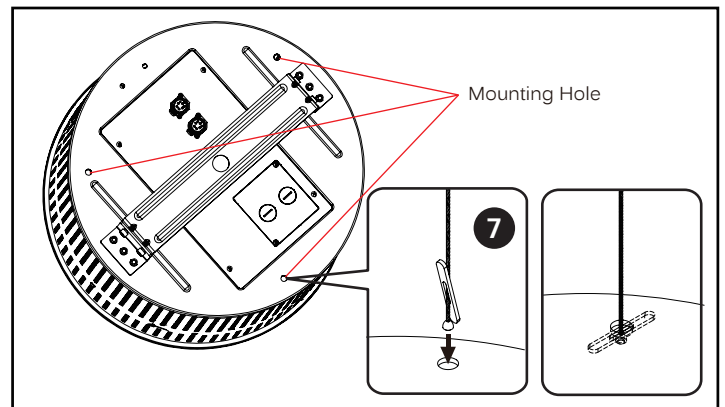
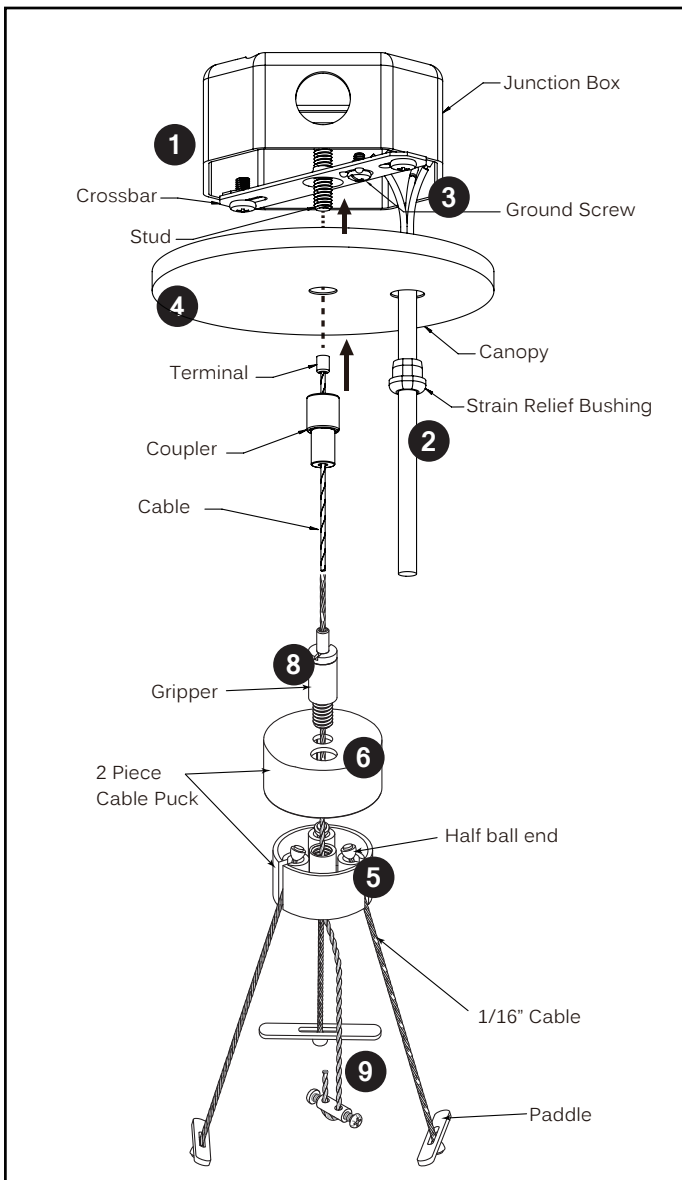

1. Secure the crossbar to the 4" octagonal box (by others) designed to support the weight of the fixture.
2. Insert power feed cord through canopy wire hole and secure with strain relief bushing. Leave sufficient length to make wire connections.
3. Make ground connection to the ground screw on crossbar. Connect line voltage to the Brown conductor, neutral to the Blue conductor.  
For 0-10V dimming option, make connections (Data+ to Purple conductor and Data- to Gray conductor).
4. Thread the cable through the coupler (the terminal side of cable must be on top). Slide the coupler up to the canopy and secure with the stud on crossbar.
5. Lay half ball end cables into lower section of cable puck.
6. Attach upper section of puck over top of bottom of puck aligning power cord holes of upper and lower section of puck. And secure gripper into top of puck completing puck assembly.
7. Attach puck assembly to fixture by dropping paddle ends of cables into the 3 holes on the back of the fixture.
8. Insert the cable through the gripper on top of puck. Adjust to desired height. Thread Cable thru both holes in Cable Locking Tube and tighten set screws.
9. Insert the cord through the puck. Trim cord to suitable length and make electric connection in the junction box for fixture.

# ADVANCED HIGH CEILING Signum 16 - Adjustable Cable



## Wiring diagram

### Superior 0-10V

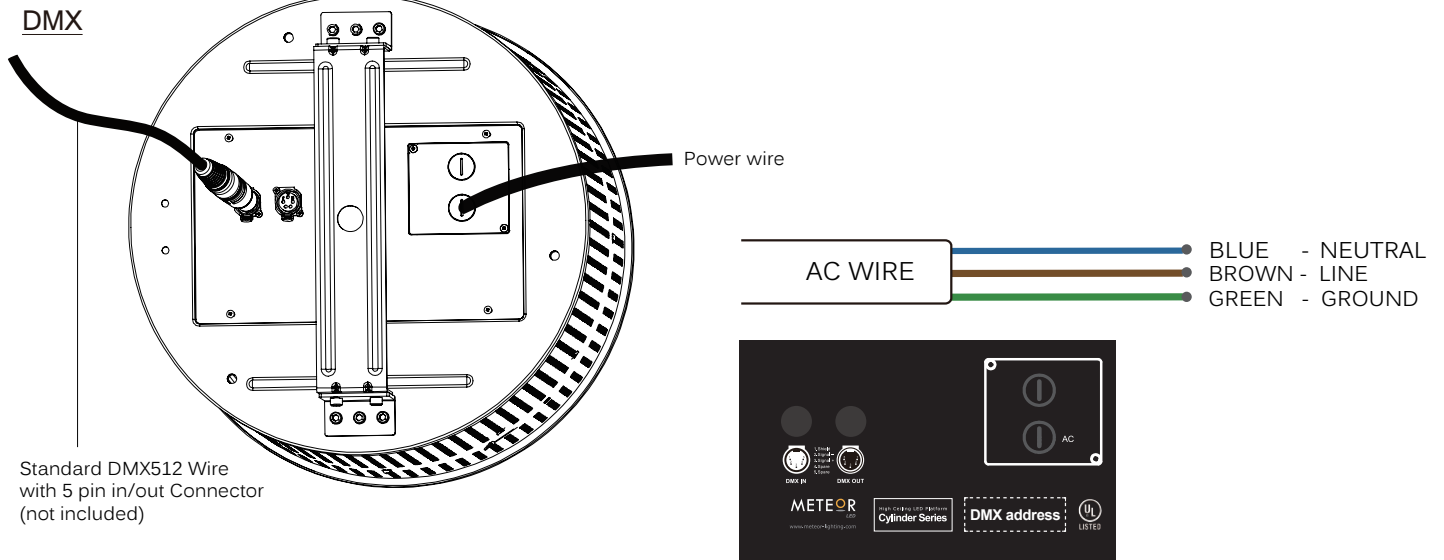
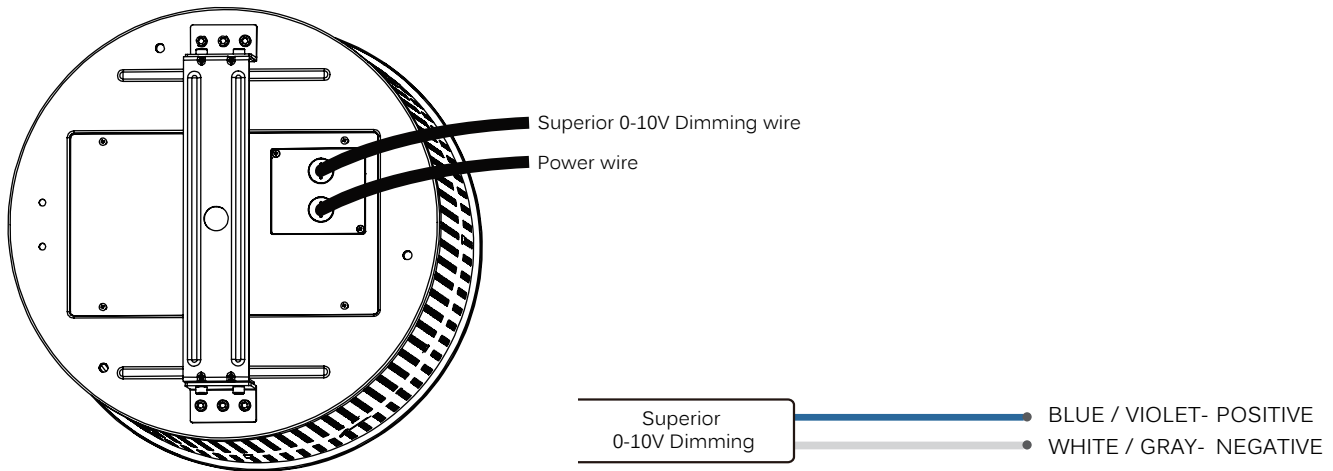

DMX512 is connected using a daisy-chain methodology where the source connects to the input of the first device, the output of the first device connects to the input of the next device, and so on.

# ADVANCED HIGH CEILING

## Signum 16 - Adjustable Cable

---



### Application note : Wiring for DMX/RDM lighting systems

DMX/RDM is a robust and reliable system for lighting control. However, if not implemented correctly, problems can arise such as random flashing of lights, erratic operation and delays in responding to commands. This document explains the best practices in DMX wiring.

### Important things to consider are:

1. DMX is a three-wire system. Use all three!
2. DMX is based on the EIA-485/RS-485 standard.
3. Always use cable specifically designed for DMX / RS-485. These cables have an impedance of  $120\Omega$  and a low capacitance. For instance : Belden 9841 or 3105a.
4. DMX must be terminated with a  $120\Omega$  resistor to prevent reflections.
5. A daisy chain topology should be used.
6. After **32** unit loads a repeater/booster should be used.  
(Important : For tunable white fixtures, After "**15**" unit loads a repeater/booster should be used.)
7. Keep cabling below 200 meters between the controller and the last driver.
8. It is generally considered good practice to provide separate DMX in and DMX out / DMX thru connections to your fixture to aid in installation. This can be in the form of pigtails, RJ-45 connectors or 5-pin XLR connectors.
9. Use twisted pair cables with an impedance of  $120\Omega$  and a low capacitance.
10. UTP Cat5 or Cat6 network cable can also be used but have a slightly lower impedance of  $100\Omega$ .
11. If shielded cable is used, only connect shield to ground on one side (typically, the controller should have its shield terminal connected to ground).
12. Not following the above recommendations may seem to work at first, but can cause problems. Sometimes after weeks of seemingly normal operation.