

IMPORTANT SAFETY INFORMATION READ AND FOLLOW ALL SAFETY INSTRUCTIONS

- Before wiring to power supply and during servicing or relamping, turn off power at fuse or circuit breaker.
- All servicing or relamping must be performed by qualified service personnel.
- Product must be grounded to avoid potential electric shock or other potential hazard.
- Product must be installed at locations and heights, in a manner consistent with its intended use, and in compliance with Electrical Code and local codes.

SAVE THESE INSTRUCTIONS FOR FUTURE REFERENCE

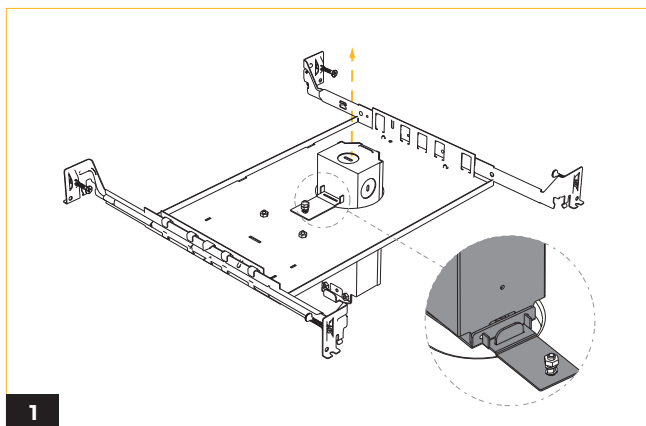

1 Align the extruded power box clip with the clasp insert on the new construction frame. Push up and hold in place.

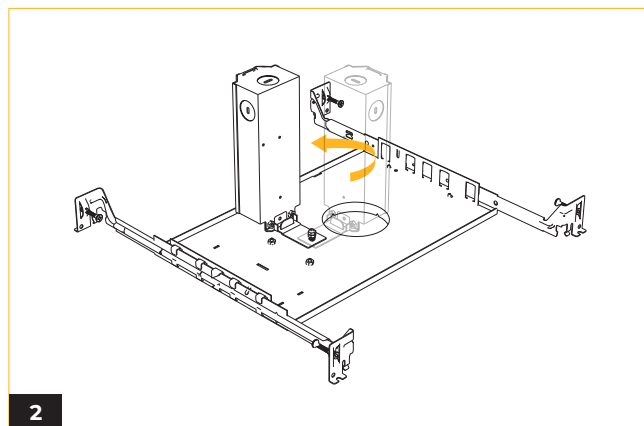

2 Push the power box aside along the alignment tracks to secure the power box and make room for the light engine.

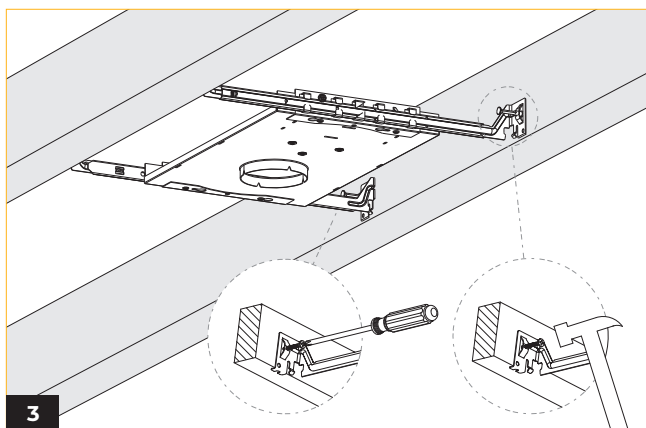

3 For installation on a wooden structure, extend the two support rails on the sides to a suitable length. Utilize the pre-installed screw/nails on the rails by either screwing or hammering them in until they are firmly fixed.

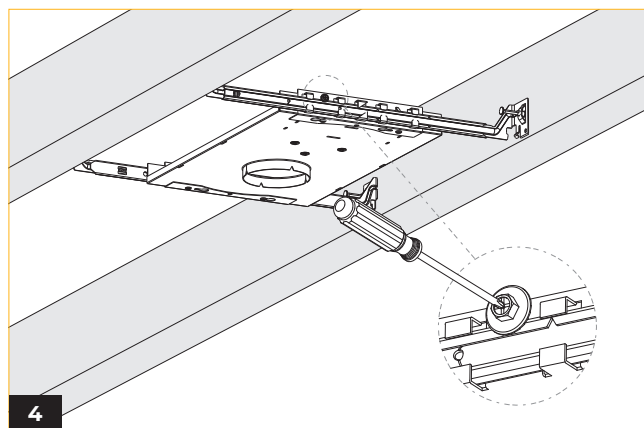

4 After securing the screw/nails in place, tighten the screws on the support rails to lock them from moving.

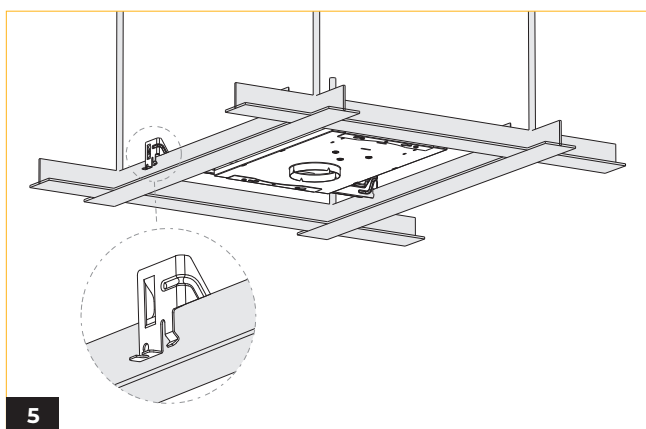

5 For installation on a grid structure, extend the two support rails on the sides to an appropriate length and secure them by hooking onto the beams.

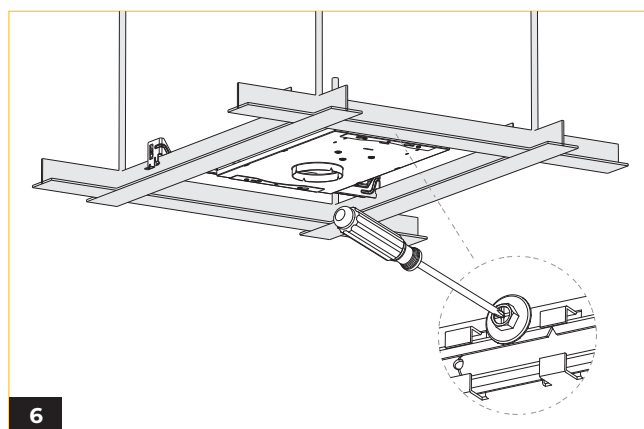

6 After securing the support rails in place, tighten the screws on the support rails to lock them from moving.

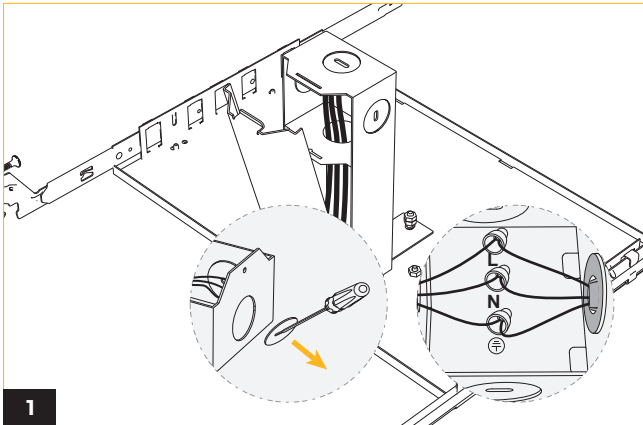

1 Remove knockout and establish connections between the power box and the electrical connection. (Refer to wiring diagram)

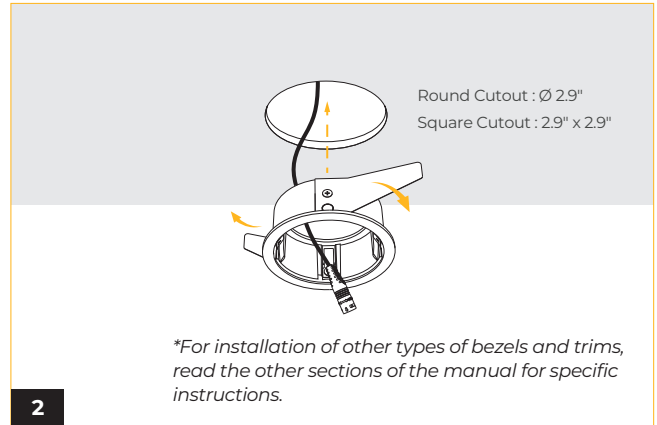

2 For installation of a round bezel fixture, apply pressure to the metal fin springs and shape them inward. Subsequently, insert the frame through the ceiling cut out.
*For installation of other types of bezels and trims, read the other sections of the manual for specific instructions.

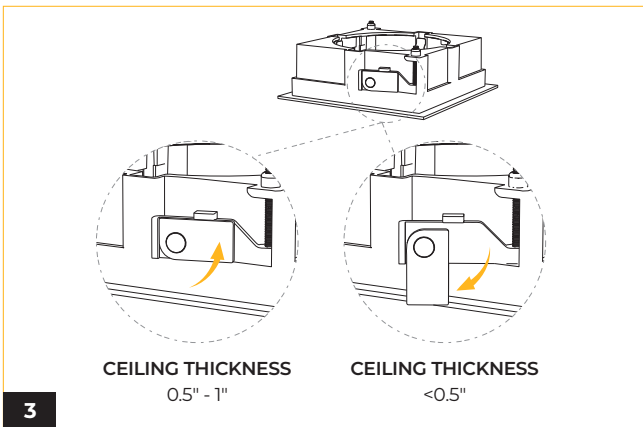

3 For installation of other bezel types, align the mounting tabs to the appropriate position according to ceiling thickness.

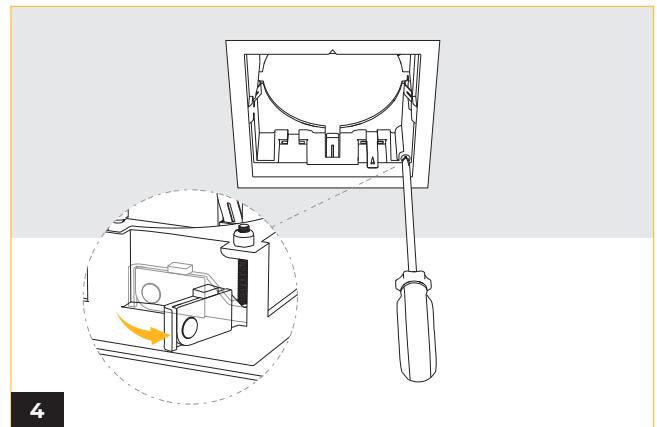

4 Install the bezel frame through the ceiling opening. Use a Phillips screwdriver to expand the two mounting tabs and secure the bezel frame in place.

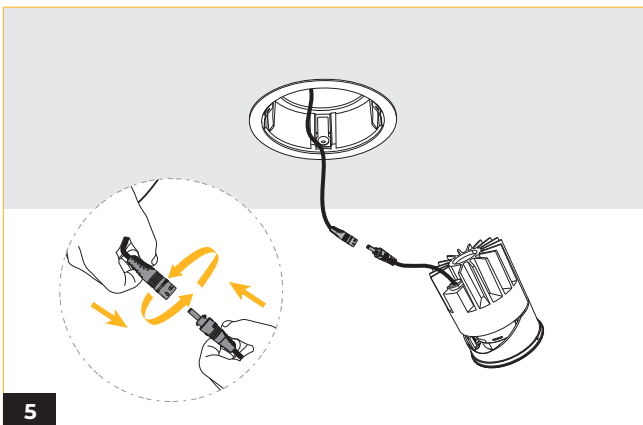

5 Establish the electrical connection between the power box and the fixture using a quick-connect wire connector. Plug the connector into place and twist until it is secure.

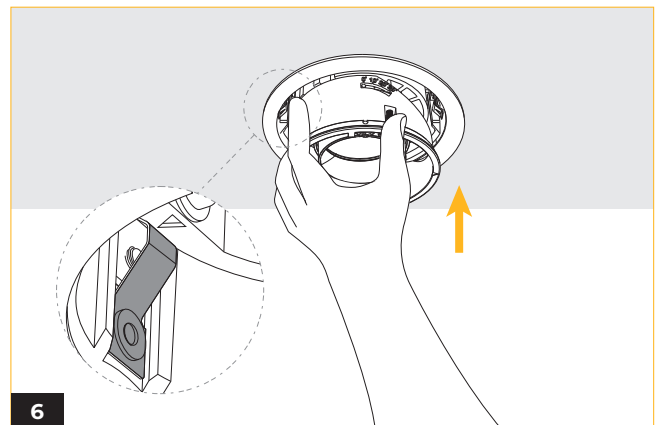

6 Install the light engine from below ceiling until it is securely fastened by the springs on the bezel frame. The secure engagement should produce a distinct clicking sound, indicating proper installation.

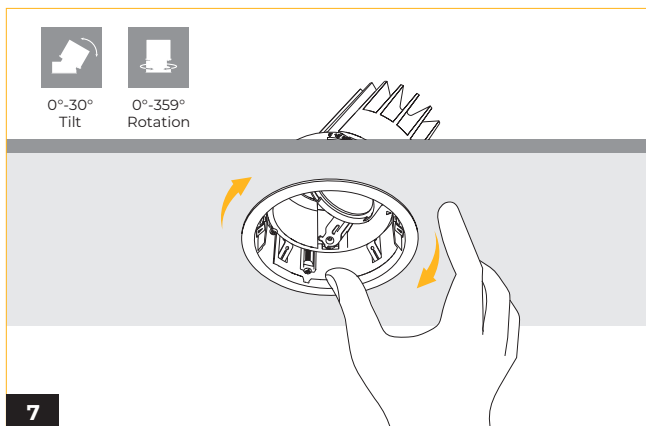

Direct the light in the desired direction by rotating and tilting the fixture.

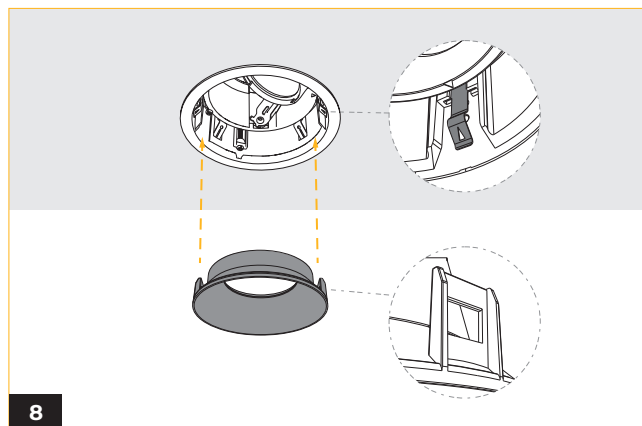

Install the trim by aligning the two clip inserts with the springs on the bezel frame. Push the trim into place until it is firmly secured by the springs on the bezel frame.

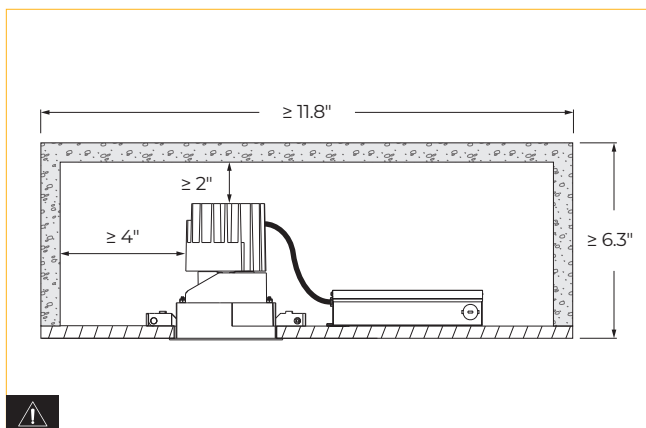

Maintain an adequate amount of clearance around the lighting fixture to ensure proper heat dissipation.

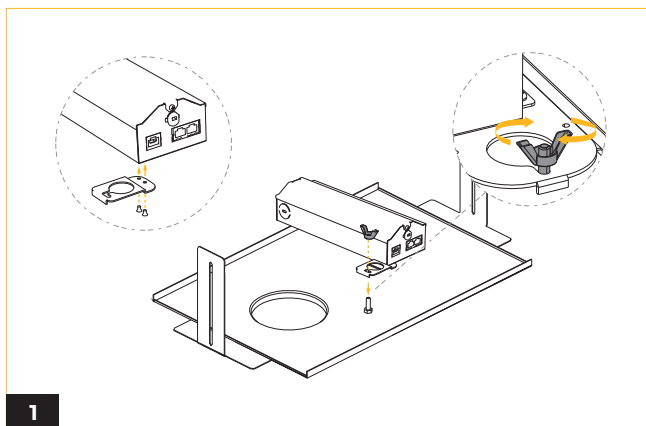

Fasten the mounting plate onto the power box by inserting and tightening two screws. Then, install the power box onto the new construction plate and secure it firmly in place using a wing nut.

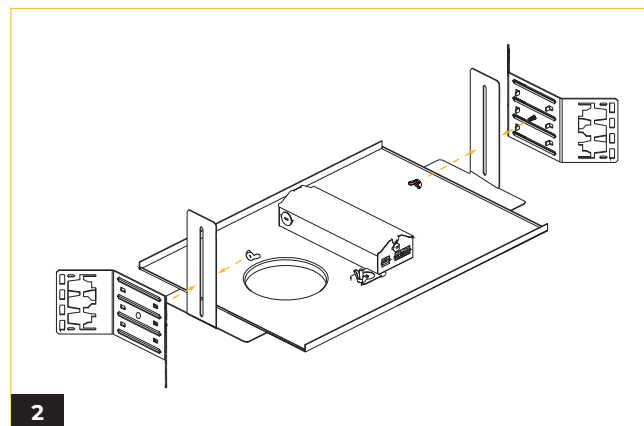

Align and attach the butterfly bracket to the side rail. Secure the butterfly bracket by screwing in the provided wing nut from behind.

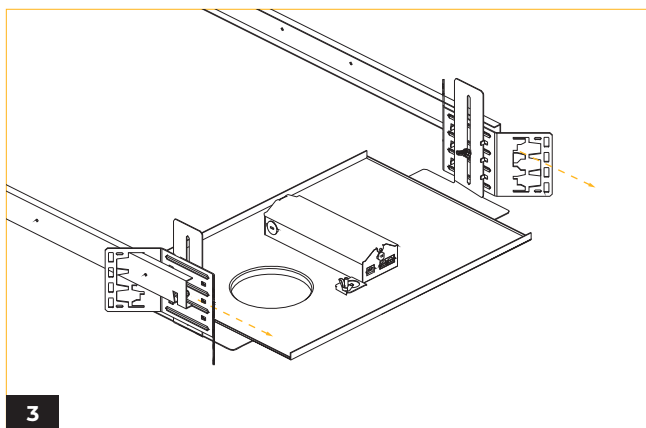

Install fixture using universal mounting bracket with slots for C-Channel (by others), bar hanger (by others) and 1/2" EMT (by others). Secure to joist or grid using hardware or wire. Adjust height as needed.

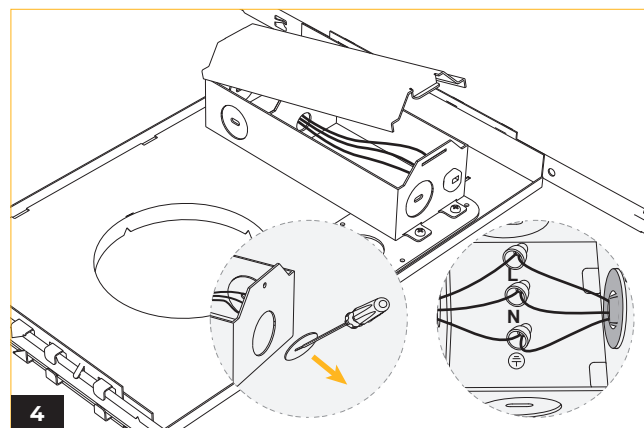

Proceed with the remainder of the installation, following the instructions outlined in 'New Construction Step 6' on Page 2.

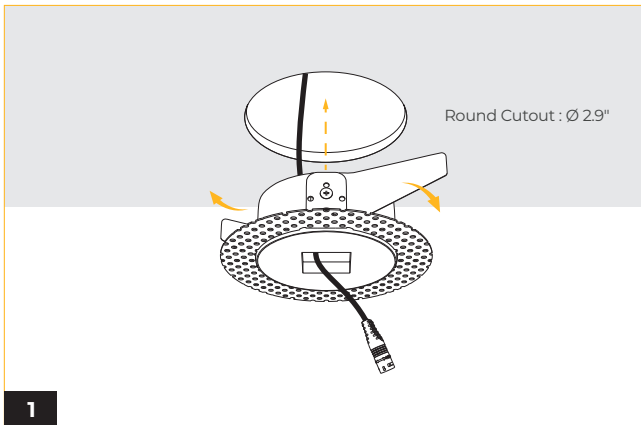

Apply pressure to the metal fin springs and shape them inward. Subsequently, insert the frame through the ceiling cut out.

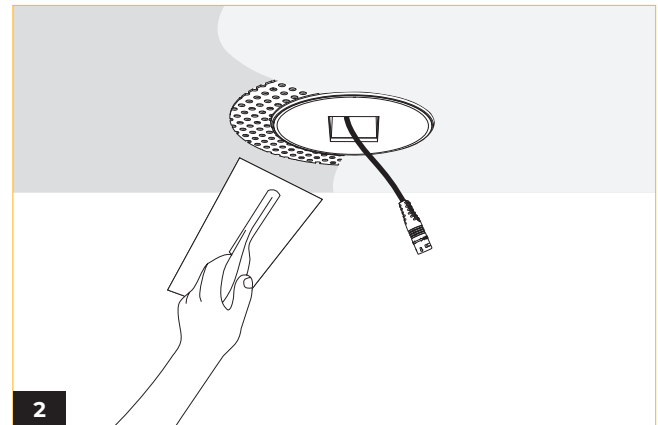

Spread the plastering compound evenly around the frame and smooth it out to create a flat surface on the ceiling. Once finished, remove the protective foam and proceed with the rest of the installation.

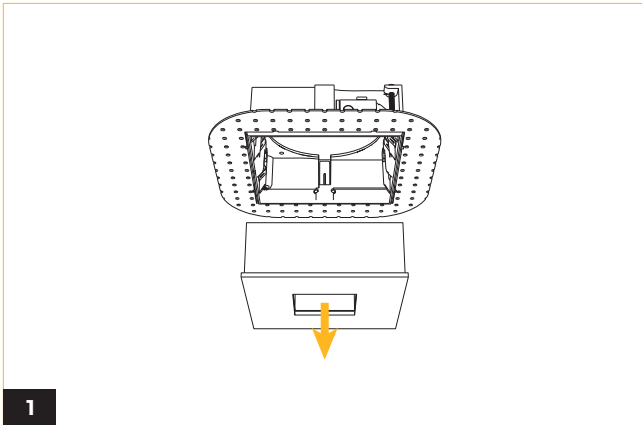

1 Remove the protective foam from the frame and retain it for later use.

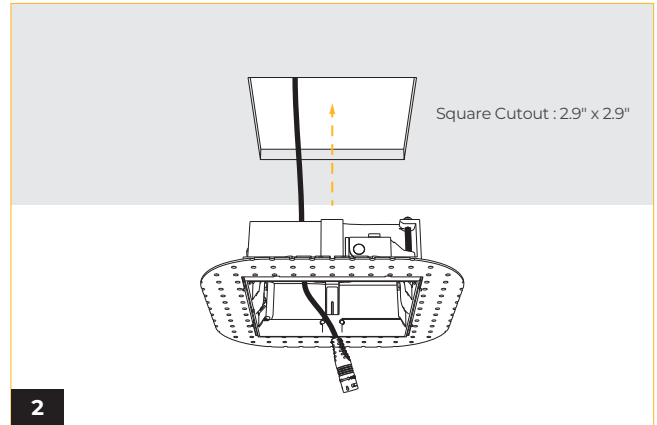

2 Insert the frame through the ceiling cut out.

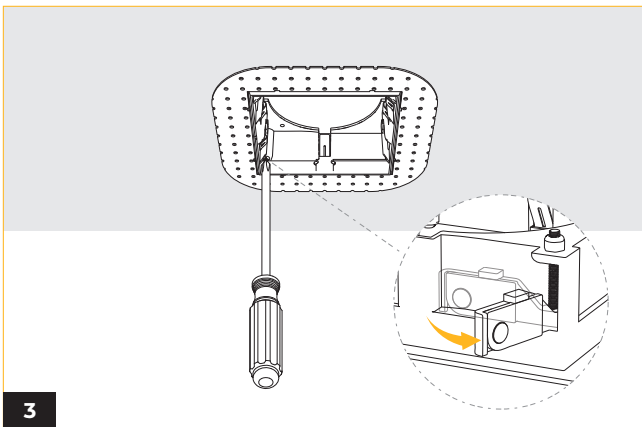

3 Use a Phillips screwdriver to expand the two mounting tabs and secure the bezel frame in place.

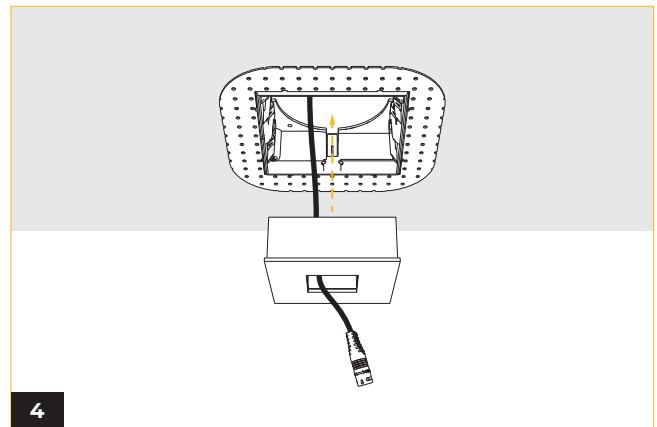

4 Place the protective foam back into the frame.

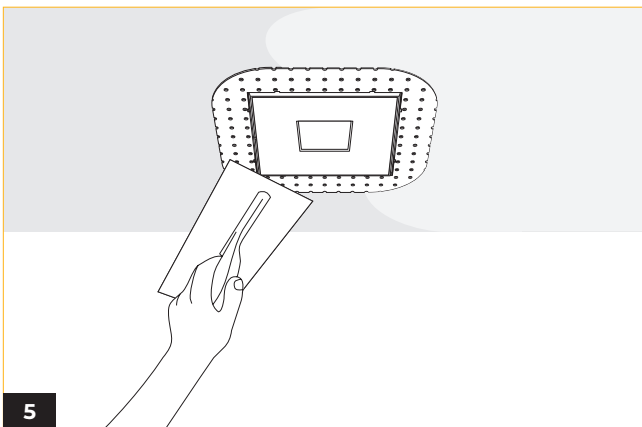

5 Spread the plastering compound evenly around the frame and smooth it out to create a flat surface on the ceiling. Once finished, remove the protective foam and proceed with the rest of the installation.

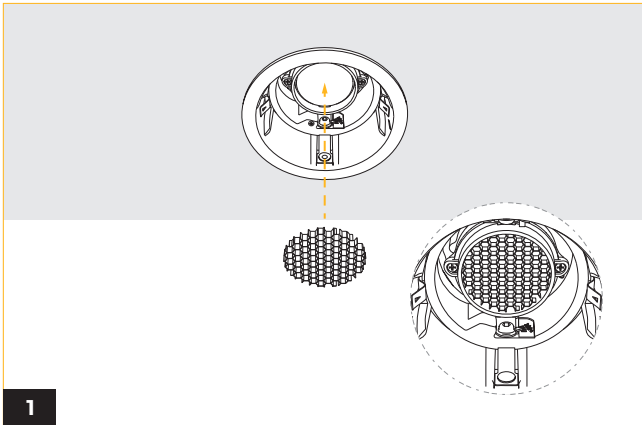

Install the honeycomb louver by placing it below the optics.

WIRING DIAGRAM

SPV

*Not to scale

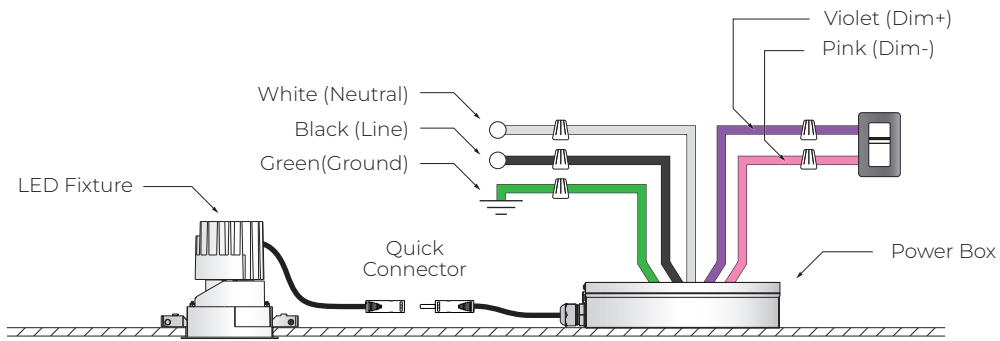

TRC

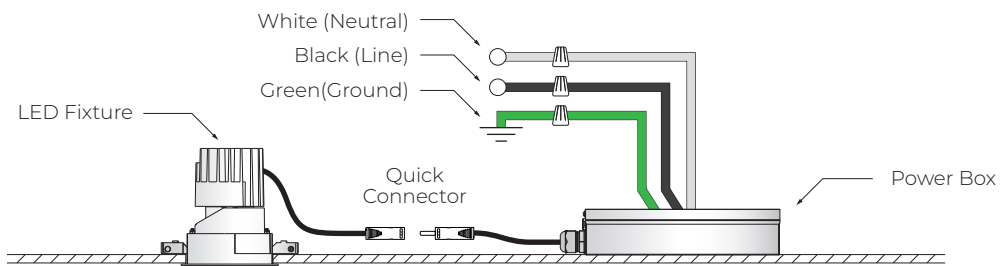

DALI

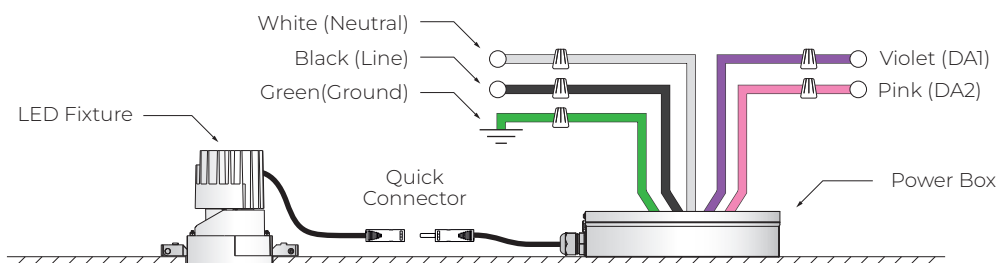

WIRING DIAGRAM

DMX Static White

*Not to scale

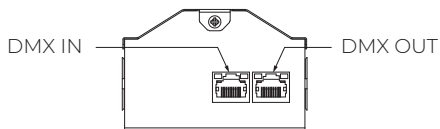
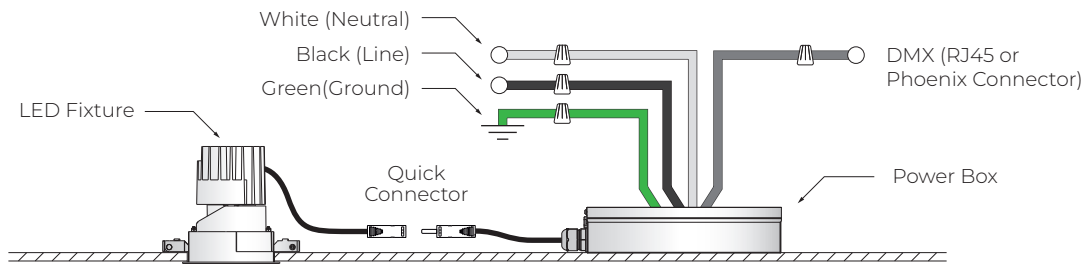

RJ45 Sockets

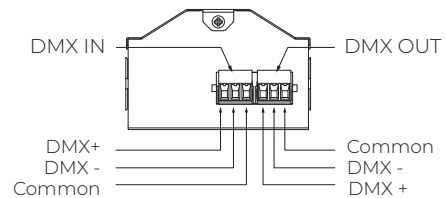

Phoenix Connector

WIRING DIAGRAM

DMX (W+RGB/Tunable White)

*Not to scale

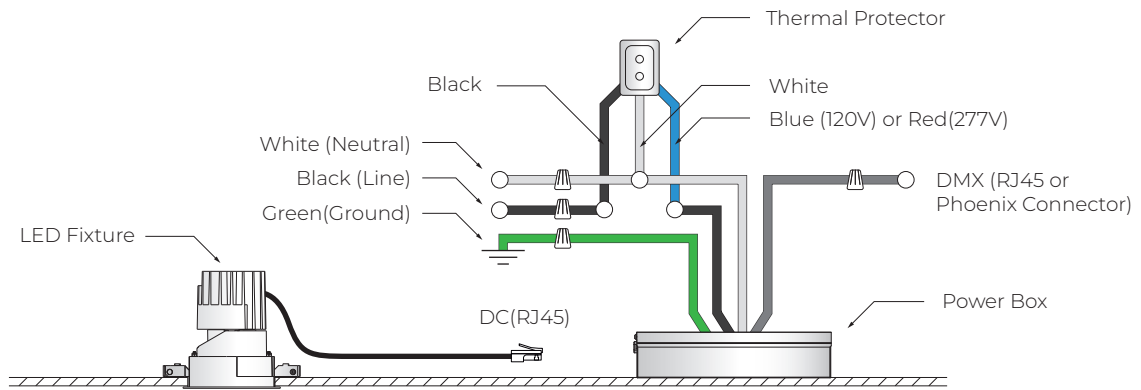

ATTENTION

DO NOT MIX THE RJ45 DC POWER OUTPUT WITH THE DMX SIGNAL, AS IT MAY LEAD TO EQUIPMENT DAMAGE OR MALFUNCTION.

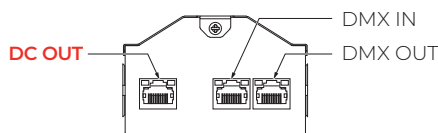

RJ45 Sockets

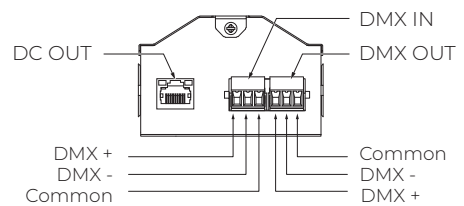

Phoenix Connector

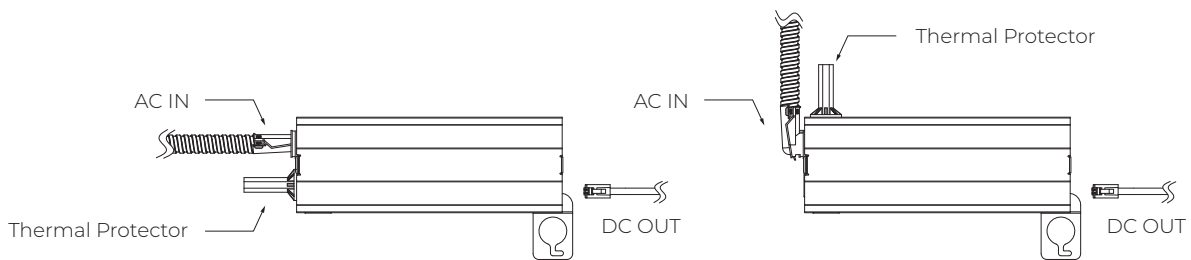

Thermal Protector Position

To facilitate the fitting of the power box through the ceiling cutout, adjust the position of the thermal protector as shown.