

IMPORTANT SAFETY INFORMATION READ AND FOLLOW ALL SAFETY INSTRUCTIONS

- Before wiring to power supply and during servicing or relamping, turn off power at fuse or circuit breaker.
- All servicing or relamping must be performed by qualified service personnel.
- When performing any wiring or electrical tasks, wear insulated gloves and ensure the product is grounded to avoid electric shock or other potential hazards.
- Product must be installed at locations and heights, in a manner consistent with its intended use, and in compliance with Electrical Code and local codes.

SAVE THESE INSTRUCTIONS FOR FUTURE REFERENCE

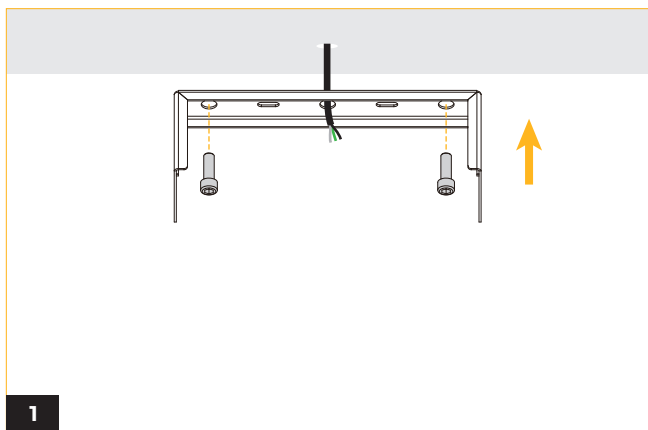
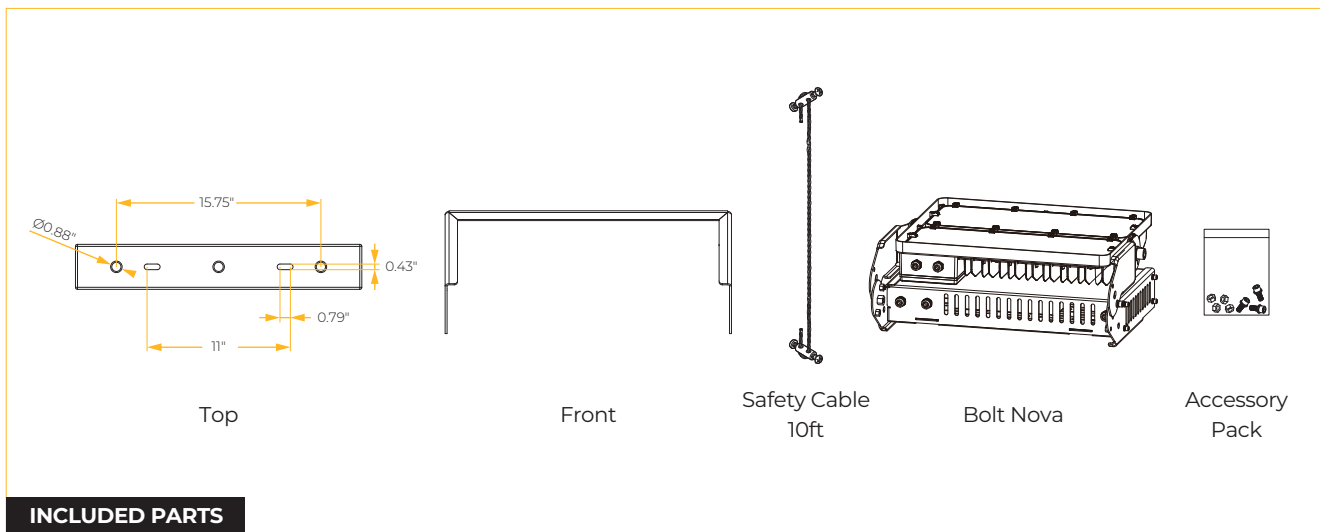

Secure the mounting bracket to a level surface using appropriate mounting hardware capable of supporting the fixture's weight. (700W: 44 lbs, 1050W: 77 lbs)

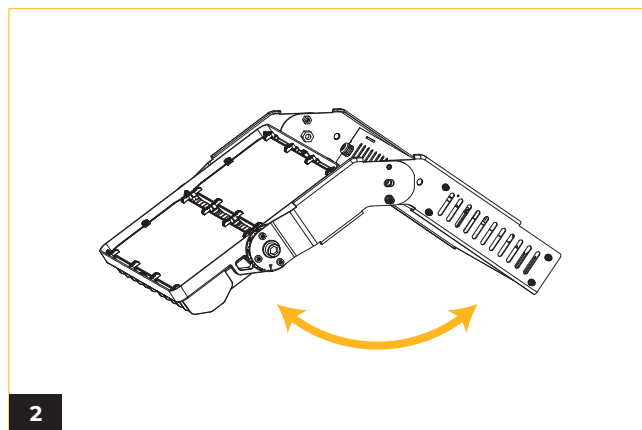

Unfold the luminaire body until the screw points are aligned.

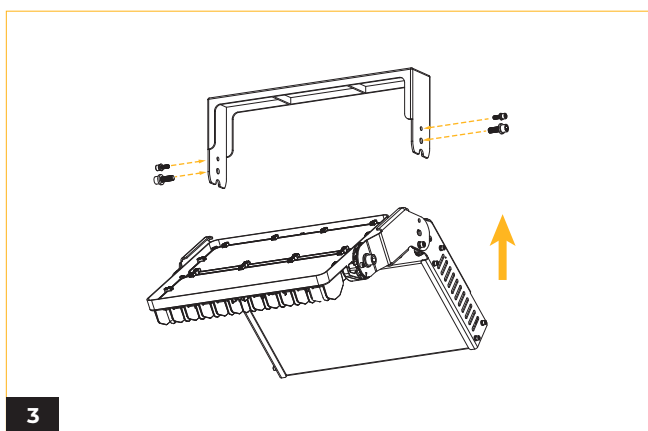

Align the bracket with the luminaire body, and fasten the bracket by using two screws on each side. Ensure that the unfolded body is also securely fixed and remains stable.

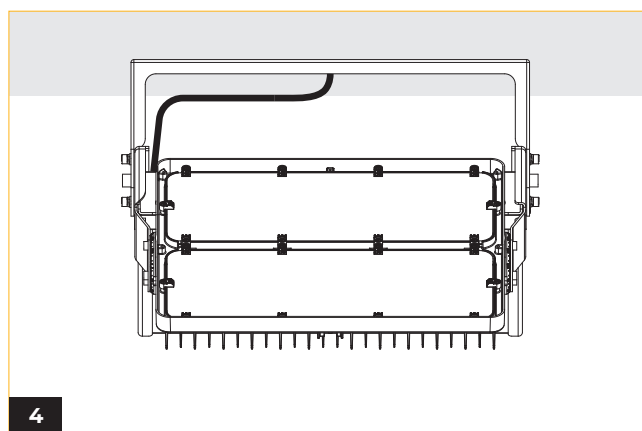

Establish electrical connections between the junction box and the fixture. (Refer to wiring diagram)

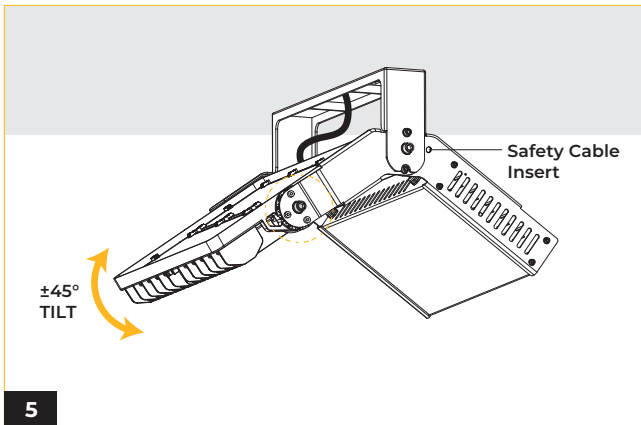

The light engine can be adjusted within a range of ± 45 degrees. To secure the rotated position, tighten the screws on each side.

WIRING DIAGRAM

NOD

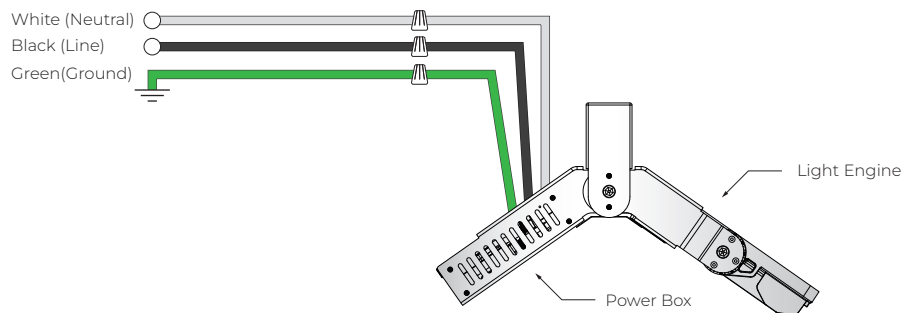

STV 1-10V

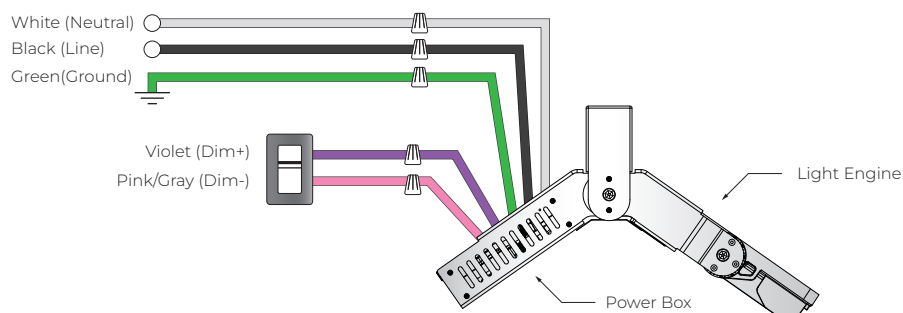

DMX

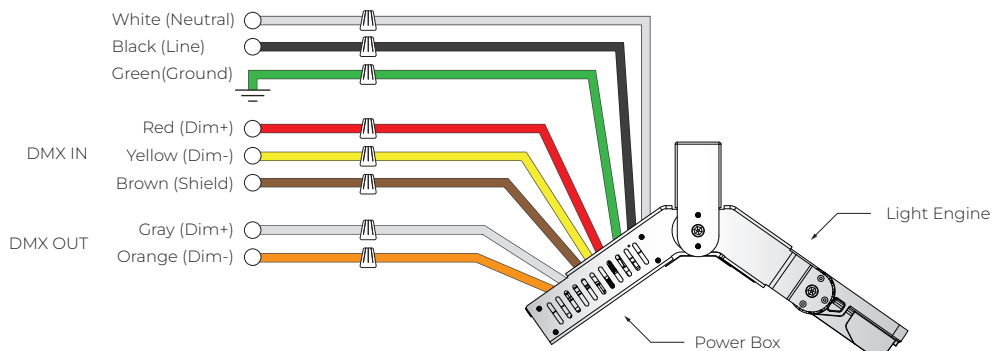

WIRING DIAGRAM

Application note : Wiring for DMX/RDM lighting systems

DMX/RDM is a robust and reliable system for lighting control. However, if not implemented correctly, problems can arise such as random flashing of lights, erratic operation and delays in responding to commands. This document explains the best practices in DMX wiring.

Important things to consider are:

1. DMX is a three-wire system. Use all three!
2. DMX is based on the EIA-485/RS-485 standard.
3. Always use cable specifically designed for DMX / RS-485. These cables have an impedance of 120Ω and a low capacitance. For instance : Belden 9729.
4. DMX must be terminated with a 120Ω resistor to prevent reflections.
5. A daisy chain topology should be used.
6. After 32 unit loads a repeater/booster should be used. (Important : For tunable white fixtures, After "32" unit loads a repeater/booster should be used.)
7. Keep cabling below 200 meters between the controller and the last driver.
8. It is generally considered good practice to provide separate DMX in and DMX out / DMX Thru connections to your fixture to aid in installation. This can be in the form of pigtails, RJ-45 connectors or 5-pin XLR connectors.
9. Use twisted pair cables with an impedance of 120Ω and a low capacitance.
10. UTP Cat5 or Cat6 network cable can also be used but have a slightly lower impedance of 100Ω .
11. If shielded cable is used, only connect shield to ground on one side (typically, the controller should have its shield terminal connected to ground).
12. Not following the above recommendations may seem to work at first, but can cause problems. Sometimes after weeks of seemingly normal operation.